

F9J GCB'L

: ± " &
 !%\$. %\$ FCK
 fG5A 9'5G: ± "%%9L7 9DH5GG<CK BŁ
 fG95:!' \$!\$) "\$!LL!\$!%G<CK BŁ
 fB@7CBH57HGBC HG<CK B': CF 7 @5F#MŁ

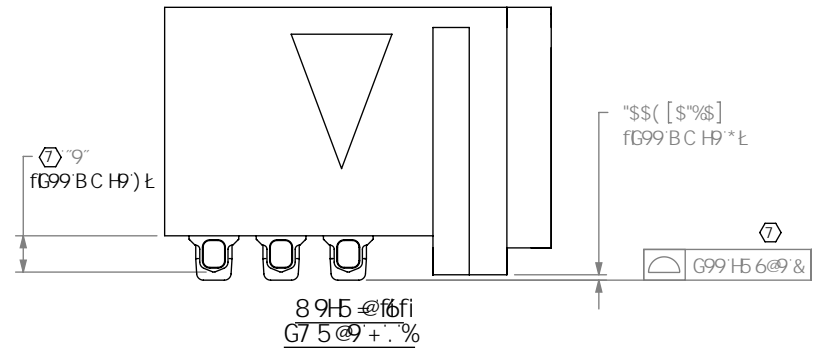
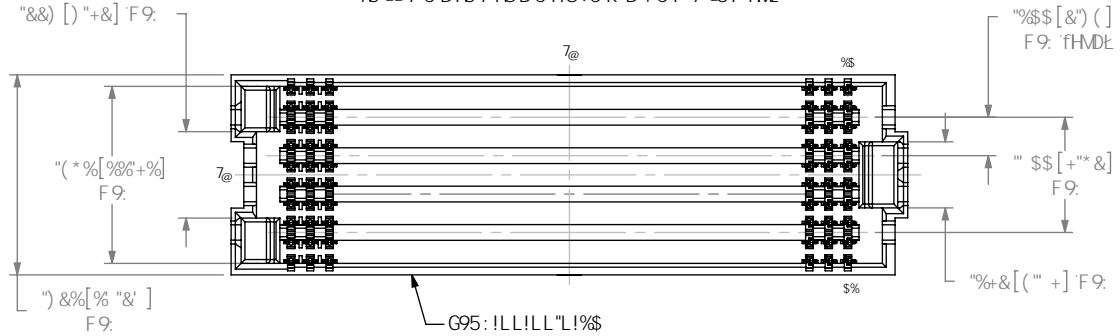

TABLE 4

POSITION	FLATNESS
-10 TO -30	.006[0.15]
-40	.009[0.23]
-50	.009[0.23]

TABLE 5

LEAD STYLE	"E"
-05.0	.0270[0.686]
-06.0	.0660[1.676]
-06.5	.0860[1.422]

: ± " " "
 !5. 5@ BA 9B HD-BGC DHC B
 fG5A 9'5G: ± "%%9L7 9DH5GG<CK BŁ
 fG95:!' \$!\$) "\$!LL!\$!%5 G<CK BŁ
 fB@7CBH57HGBC HG<CK B': CF 7 @5F#MŁ

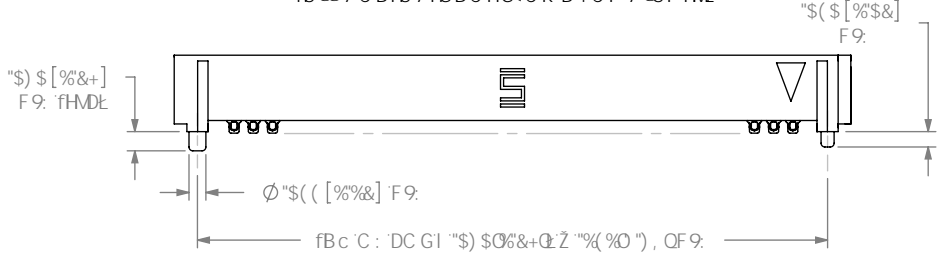

: ± " ("
 !? . ?5 DHC B' D58' C DHC B
 fG95:!' \$!\$) "\$!LL!\$!%? G<CK BŁ
 fG5A 9'5G: ± "%%9L7 9DH5GG<CK BŁ
 fB@7CBH57HGBC HG<CK B': CF 7 @5F#MŁ
 fK5B8 D@7 9I G9?!,)!*\$) ŁŁ

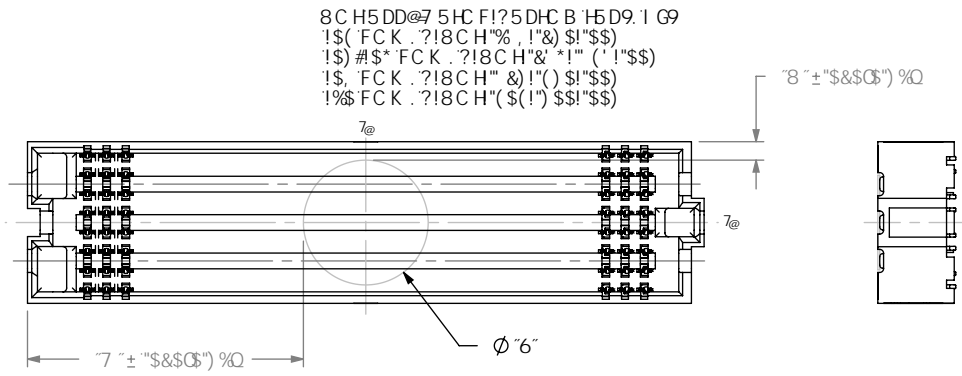
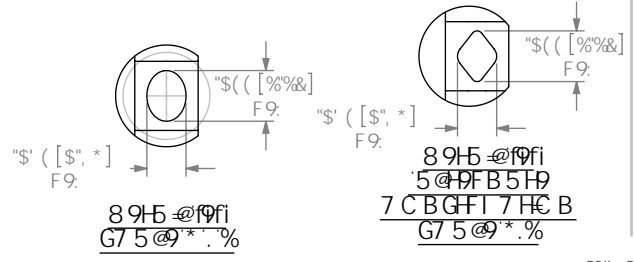

TABLE 3

ROW	"B"	"C"	"D"
-04	0.138 [3.50]	(((No OF POS x .050[1.27]) + .263[6.68]) - "B") / 2	0.042 [1.07]
-05, -06	0.236 [6.00]		0.043 [1.09]
-08	0.325 [8.25]		0.048 [1.22]
-10	0.404 [10.25]		0.059 [1.50]

TABLE 6

No. OF ROWS	"F"
-04	.079[2.01]
-05	.120[3.05]
-06	.120[3.05]
-08	.120[3.05]
-10	.120[3.05]



DFC DF 9H5 FMBC H9
 H: GBC 71A 9B H7 CBH5 BG B: CFA 5HC B
 7 C B: @9B H5 95B8 DFC DF 9H5 FMBC
 GSA H97 2 87 5B8 G: 5@BCH H59 F9DFC 81 7 98
 CF HF5BG 9F98 HC CH: 9F 8C 71A 9B HG CF
 8 47 @C 98 HC CH: 9F GCF 1 G98: CF 5BM
 DI DFC 99 CH: 9F H: 5B H: 5HK <7 < #K 5G
 C 6H5 B 98 K #C I H: 9 9L DF 9098 K F #H8
 7 C B 98 HC: GSA H97 2 87 "

8C ' BCH G7 5 @9 8F5K B:
 G: 99H G7 5 @9 & %

samtec

)&\$ D5F? 95GH6@ 8ZB9K' 5 @5BM B' (+) \$
 D<C B 9'; %&L - ((! * + SL; %&L - (,) \$ (+
 YIA UJ; .)Z 4 GSA H97 Wc a Wc XY.)')& &

8 9G7 F @HC B.
 "\$) \$ D#7 < GC 7 ? 9H5 FF5 M5 GG9A 6 @M
 8K: " BC"
G95: !LL!LL"L!LL!LL!LL
 6M 6F5H7 < 9F \$) #&+#&\$\$(G< 99H & C: *

F9J GCB'L

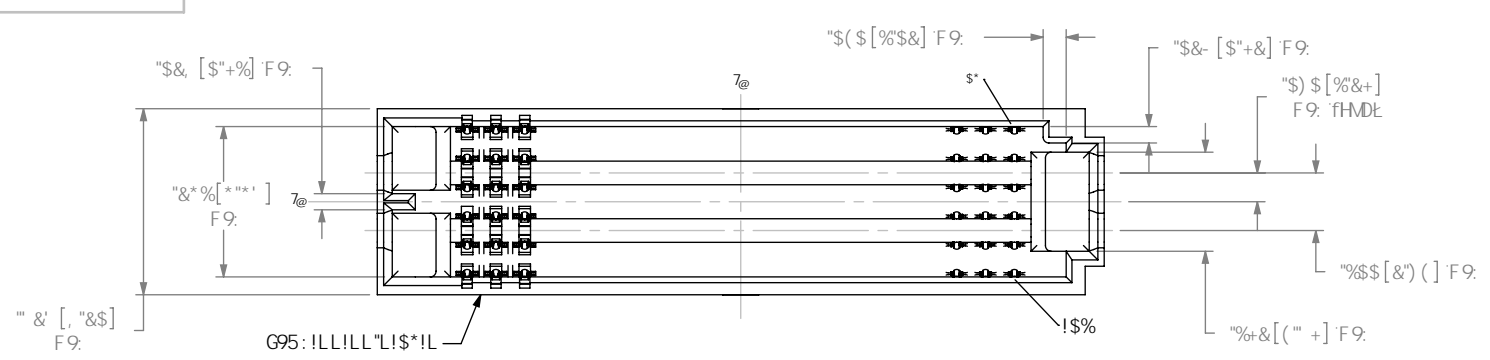

: ≙ "="

!\$"*.** FCK

fG5A 9'5G: ≙ " %Z 9L 7 9DH5GG<CK B L

fG95: !&\$!\$" !L L L \$ * ! % 5 ' G<C K B L

fB @ 7 C B H 5 7 H G B C H G<C K B : C F ' 7 @ F + M L

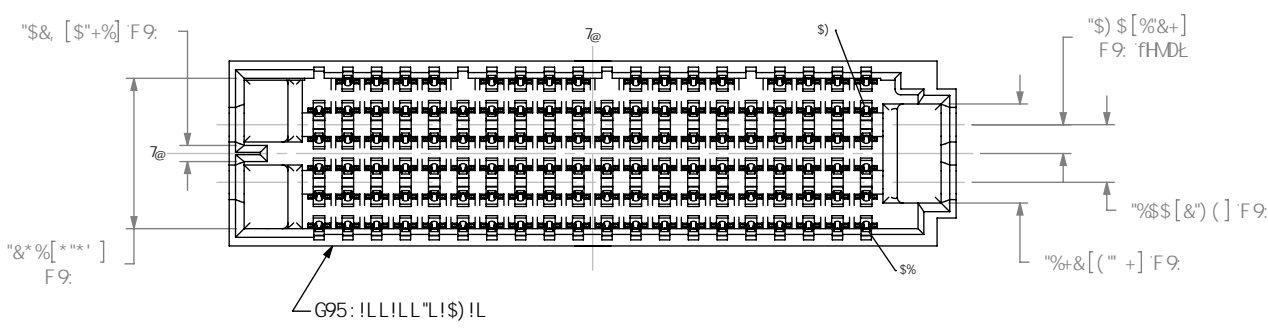

: ≙ ""*

!\$) .) FCK

fG5A 9'5G: ≙ " %Z 9L 7 9DH5GG<CK B L

fG95: !&\$!\$" !L L L \$! % 5 ' G<C K B L

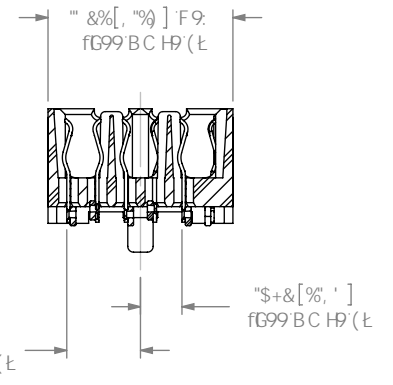
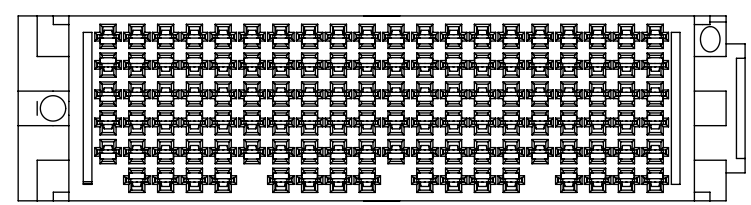
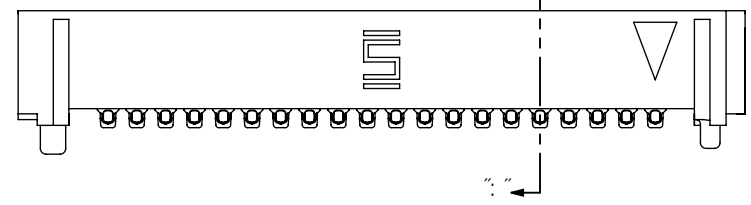

G97 H C B " : " ! " : "

DFC.DF-9H5 FMBCH9
H: GBC 71 A 98H7 C B15 BG B: C FA 5HC B
7 C B: 898H5 95B8 DFC DF 98FMM C
GSA H7 2 B 7 " 5B8 G-5MB C H 69 F90FC 81 7 98
C F H F5B G 9 F 98 H C C H: 9F 8 C 71 A 98H G C F
8 47 @ 98 H C C H: 9F G C F I 98 : C F 58 M
DI FDC 09 C H: 9F H: 5B H: 5HK < ? < #H 5G
C 615 B 98 K + k C I H H: 9 9 L D F 9098 K F # 98
7 C B 98 H C : GSA H7 2 B 7 "

8C ' B C H G 7 5 @ 9 8 F 5 K B :

G: 99 H G 7 5 @ 9 % S " * * * * *

samtec

) &\$ D5 F? 95GH6 @ 8ZB 9K 5 @ 5B M B (+) \$
D < C B 9 ; % & L - ((! * + " : ;) , & - (,) \$ (+
Y I A U J : ; & z 4 G S A H 7 " W a " W X Y .) ' &&

89G7 F 0HC B.
"\$) \$' D#7 < 'GC 7 ? 9H5 FF 5M5 GG9A 6 @M

8K : " BC "

G95: !LL!LL"!L L L L L L L L L

6M 6F5H7 < 9F \$) # & + # & \$ \$(G < 99H " " C : *

G95:!' \$!\$)""\$!LL!%\$!&!\$(
 DBGCA #H98 %&ž% ž%ž%ž&(ž&) ž&, ž&-

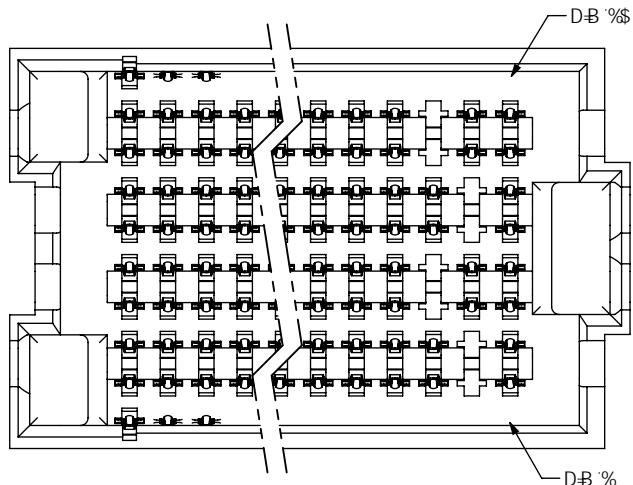

G95:!' \$!\$)""\$!LL!%\$!&!\$(
 DBGCA #H98 %&ž% ž%ž%ž&(ž&) ž&, ž&-
 ' &ž' ' ž' *ž' +ž((ž())ž(, ž(-ž

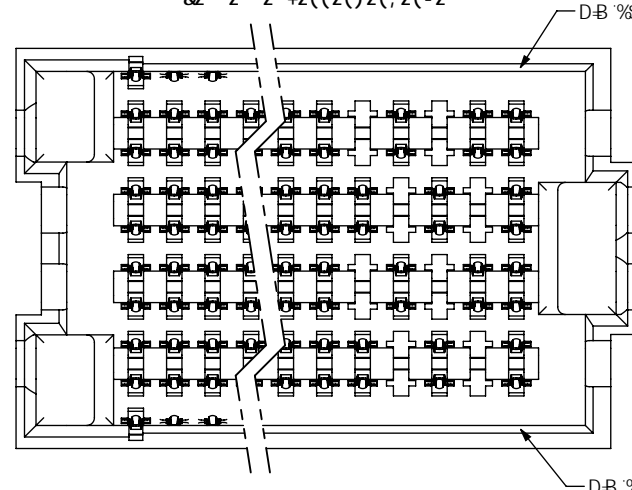

G95:!' \$!\$)""\$!LL!%\$!&!%&
 DBGCA #H98 %&ž% ž%ž%ž&(ž&) ž&, ž&-
 ' &ž' ' ž' *ž' +ž((ž())ž(, ž(-ž
)&ž)' ž)' ž)' +ž*(ž*)ž*, ž*-ž

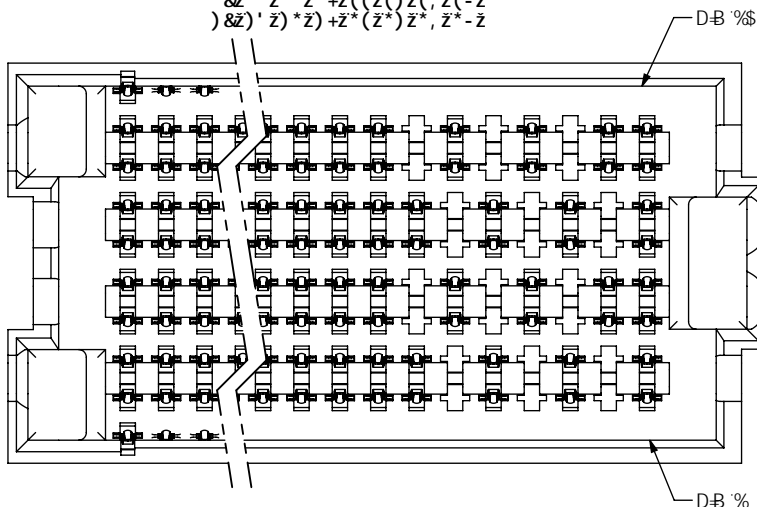

G95:!' \$!\$)""\$!LL!%\$!&!%&
 DBGCA #H98 %&ž% ž%ž%ž&(ž&) ž&, ž&-
 ' &ž' ' ž' *ž' +ž((ž())ž(, ž(-ž
)&ž)' ž)' ž)' +ž*(ž*)ž*, ž*-ž
 +&ž+' ž'+ž'+ž, (ž,)ž, /, -

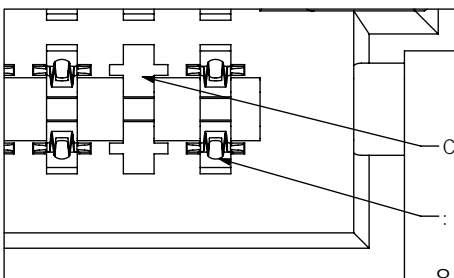
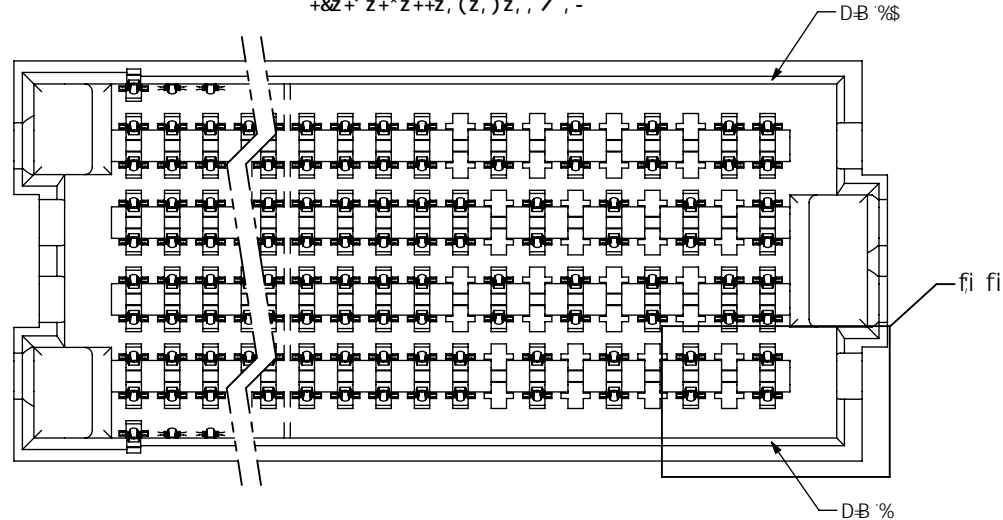

CA #H98

: @98

8915 @fi fi
 G75 @, . %

DFC DF 915 FMBC H9

H: 6BC 71A 98H7 C B16 BG B: CFA 5HC B
 7 C B: 89815 9588 DFC DF 945 F1MC
 GSA H97 2 87 588 G: 588BC H69 F90FC 81 798
 CF HF58G 9F98 HC CH: 9F 8C 71A 98H6CF
 8 47 @C 998 HC CH: 9FGCF I 998: CF 58M
 DI FDC 09 CH: 9F H: 5B H: 5HK < 7 < 4HK 5G
 C 615 898 K H: C I H: 9 9 L DF 90998 K F #H98
 7 C B 98HC: GSA H97 2 87 *

8C BCHG7 5 @9 8F5K B:

G: 99HG7 5 @9 (. %

samtec

)&\$ D5F? 95GH6@ 8ZB 9K 5 @5BM B (+) \$
 D<C B 9 ; %&L - ((! * + SL ; %&L - () \$) (+
 YIA UJ ; žž 4 GSA H97 Wc a Wc XY.)') &&

89G7 F @HC B:

"\$) \$ D+7 < GC 7 ? 9H5 FF 5 M5 GG9A 6 @M

8K : "BC"

G95: !LLILL "LILL!LL!LL!LL

6M 6F5H7 < 9F \$) #&+ #&\$\$(G< 99H)"C: *

